



EXAMINATION FOR AUTHORISATION A

Paper 2

Date: Thursday 29th January 2026

Time: 15.30 – 18:30 (Three hours)

Write only your Index Number in the space provided in the booklet.

This examination paper includes six questions. Candidates are requested to choose and answer any FIVE questions clearly indicating the question number of the answered questions.

Candidates are requested to answer ALL FIVE questions in the booklet correctly listing the answered question number in the space provided on the booklet's front sheet.

Answers should be written in Blue/Black Ink. Diagrams can be drawn in pencil.

All answers should include the necessary workings, diagrams and formulae.

Use a separate page for each different question.

Each question carries 20 marks.

1. (a) Define Ohm's Law. (2 marks)

(b) Refer to the series-parallel circuit arrangement shown in Figure 1 below and calculate the:

i) supply current (3 marks)

ii) current flowing through each resistor (4 marks)

iii) p.d. across each resistor. (6 marks)

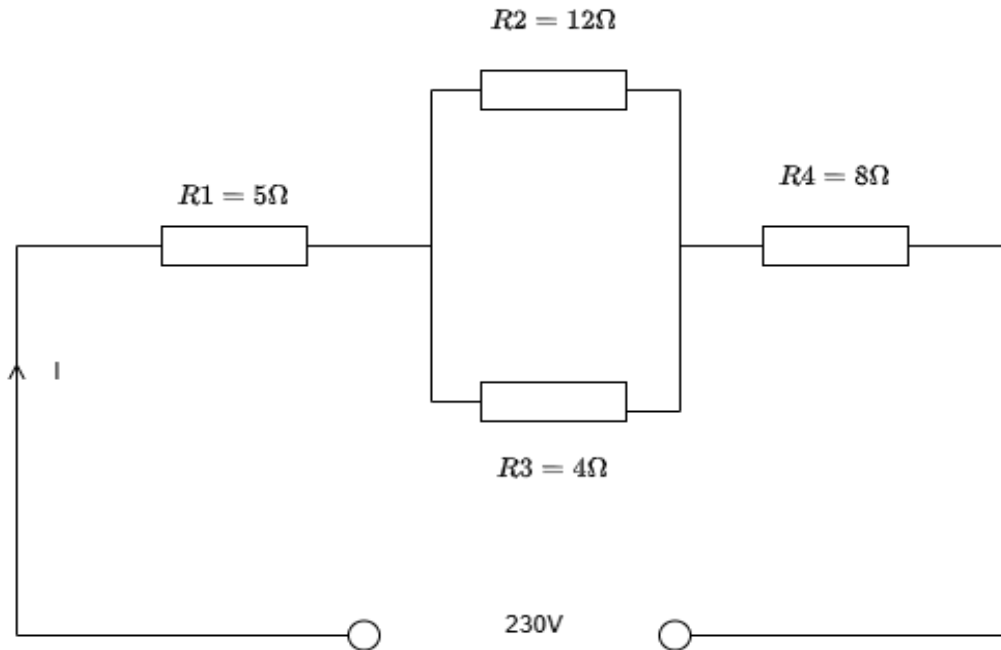

Figure 1

(c) A direct current of 4 amps flows into an uncharged 33 μF capacitor for 3 milliseconds. Determine the p.d. between the plates. (5 marks)

2. A coil having an inductance of 159.2 mH and resistance of 25 ohms is connected in series with a 60 ohms resistor. The circuit is connected to a 230V, 50Hz supply.

(a) Draw the circuit diagram for this series circuit. (2 marks)

(b) Calculate the:

i) impedance of the circuit (3 marks)

ii) current in the circuit (2 marks)

iii) circuit phase angle (2 marks)

iv) p.d. across the 60 Ω resistor (3 marks)

v) p.d. across the coil. (4 marks)

(c) Draw the circuit phasor diagram showing all voltages. (4 marks)

3. (a) Explain the term “voltage drop”. (2 marks)

(b) A 4kW, 230V at power factor 0.9, 50Hz single-phase motorised grill unit is installed in a take-away mobile unit. A portable generator is used to supply electricity to the mobile unit by means of a double pole HRC fuse switch outlet. The total distance from the portable generator to the take-away mobile unit is 25 meters. A multi-core 70°C thermoplastic non-armoured copper cable is directly clipped on a masonry wall. The ambient temperature is expected to be 40°C. The multi-core cable is grouped (touching) with another multi-core cable throughout the route. Given the tables 3A, 3B, 3C and 3D in the separate sheets,

i) calculate the practical rating of the High Rupturing Capacity (HRC) fuse protecting the cable and the grill unit (2 marks)

ii) state the corresponding “BS standard” number for the HRC fuse used. (2 marks)

iii) calculate the minimum size of the cable. (12 marks)

iv) work out the voltage drop as a percentage of the nominal supply voltage. (2 marks)

4. (a) Explain the difference between each of the following terms and give **ONE** application of each.

i) PVC conduit and Steel conduit (4 marks)

ii) Skirting and standard trunking (4 marks)

iii) Cable ladder and cable tray (4 marks)

iv) Single core PVC insulated cable and Multi core armoured cable (4 marks)

(b) i) Name **THREE** components used to terminate a steel conduit into a 3x3 or 6x3 steel box. (3 marks)

ii) What are the precautions taken during the threading of the steel conduit? (1 mark)

5. (a) A bathroom floor heating is to be installed underneath the tiling. The floor heating element is to be installed in four separate circuits.

Read the following **FIVE** statements (A to E) and state which statements are incorrect. Give a reason for each incorrect statement you list. (12 marks)

- A. Under-floor heating must have either an integrated earth conductive sheath along its length or else a conductive earth square mesh must be installed above the heating cable with some distance apart.
- B. Under-floor heating can only be installed in commercial places such as hotels where there is available 3-phase power supply.
- C. In a bathroom, floor heating can be installed in Zone 2 and Zone 3.
- D. The under-floor heating elements do only require to be protected against overcurrent or short circuit devices but do not require to be protected by an RCD or any earth leakage device since it is very unlikely that one can come in contact with any live part.
- E. The under-floor heating termination block for each 4 separate circuits can only be installed in Zone 3 inside the bathroom hidden behind or under an easily removable tile.

- (b) You are required to install a single-phase 230V electric underfloor heating system in a residential bathroom with dimensions 4m x 4m. The heating mat is rated at 250 W/m^2

- i) Since there will be four separate final circuits, calculate the surface area that has to be provided by each circuit. (2 marks)
- ii) Calculate the current drawn by each floor area segment. (2 marks)
- iii) The customer wants to protect each circuit separately using RCBO's. What is the rating of the RCBO's (overcurrent rating and residual current rating)? (1 mark)
- iv) What is the expected resistance of each heating segment? Mention **TWO** stages deemed necessary to measure this resistance during installation to make sure that the installation is good before laying and locking with tiles. (3 marks)

6. (a) i) Explain the difference between a moving coil and a moving iron ammeter. (4 marks)
- ii) Which device can be used to measure AC currents? (1 mark)

(b) A moving iron ammeter has a full-scale current of 5A. The number of segments across the range is 10.

A Current Transformer, having a ratio of 120/ 5A is connected to the ammeter.

- i) Describe how a Current Transformer works. (4 marks)
- ii) A load, not greater than 40A, is to be measured by the ammeter. The full scale of the ammeter is 40A, how many turns the primary circuit need to be wound to the CT core so that the ammeter reads 40A at full scale? (4 marks)
- iii) Draw up the wiring diagram. (4 marks)
- iv) How much current does each segment of the ammeter scale represent? (3 marks)

END OF EXAMINATION PAPER

BLANK PAGE

BLANK PAGE

BLANK PAGE