



EXAMINATION FOR AUTHORISATION B

Paper 2

Date: Friday 30th January 2026

Time: 15.30 – 18:30 (Three hours)

Write only your Index Number in the space provided in the booklet.

This examination paper includes six questions. Candidates are requested to choose and answer any FIVE questions clearly indicating the question number of the answered questions.

Candidates are requested to answer ALL FIVE questions in the booklet correctly listing the answered question number in the space provided on the booklet's front sheet.

Answers should be written in Blue/Black Ink. Diagrams can be drawn in pencil.

All answers should include the necessary workings, diagrams and formulae.

Use a separate page for each different question.

Each question carries 20 marks.

1. (a) Consider a parallel RLC network. Explain with the aid of a diagram what is meant by resonance and when it occurs. (4 marks)
- (b) A 33 μF capacitor is connected in parallel with an 80Ω resistor across a 230V, 50Hz supply. Calculate the following:
- (i) current in each branch (5 marks)
 - (ii) supply current (3 marks)
 - (iii) circuit phase angle (2 marks)
 - (iv) circuit impedance (2 marks)
 - (v) power dissipated (2 marks)
 - (vi) apparent power. (2 marks)

2. (a) Explain why inrush current occurs when starting an AC induction motor. (3 marks)
- (b) This inrush starting current can cause several effects to the electrical installation system and the equipment or devices connected to it. List and explain **THREE** effects caused by the inrush starting current. (6 marks)
- (c) There are several methods for starting AC induction motors. The two starters below are commonly used in industry.

- Direct-on-line (DOL) starter
- Star-Delta Starting

- (i) Explain the difference that exists between the two methods of starting. (3 marks)
 - (ii) For each respective method of starting, state **TWO** advantages and **TWO** disadvantages. (8 marks)
3. (a) A carpenter workshop manufactures several types of furniture. The workshop consumes a substantial amount of electricity. The average daily measurement of current exceeds 60 amps per phase, hence in accordance with the Electricity and Supply Regulations the energy meter installed by the Distribution System Operator (Enemalta) measures the maximum demand and the energy consumed in kWh. Explain the difference between registered energy consumed in kWh and the registered maximum demand in kW. (6 marks)

- (b) The following table (Table 3.1) shows the machine loads required to be used during a normal working day. The supply voltage is three-phase 400V, 50Hz and the power factor is measured at 0.6.

Machine	Rated demand	Diversity factor	Type of starter	Machine description
A	20kW	50%	Soft starter	Wood press
B	15kW	80%	Soft starter	Cutting machine
C	10kW	30%	Star/delta starter	Lathe machine
D	5kW	90%	Star/delta starter	Electric saw
E	1.5kW	20%	Direct-on-line	Wood sharpeners
F	8kW	95%	Star/delta starter	Sanders

Table 3.1

Referring to Table 3.1 above, calculate:

- (i) the maximum demand, if machines A, D and E are switched on together within the period of 30 minutes. (2 marks)
- (ii) the cost of the maximum demand (for machines A, D, E) for three-months. The recorded maximum demand value of the kW is as per result obtained in item (i) above. Assume maximum demand rate for 12 months is €20.5 per kW. (4 marks)
- (iii) using the diversity factors provided in the table above, work out the total load demand within the carpenter workshop and state the recommended main 4-pole MCCB rating. (8 marks)

4 (a) Define the term 'cable trunking'.

(2 marks)

(b) A 3-phase 4 wire TT System is feeding a small workshop which consists of several electrical hand tools and machinery. The warranted engineer instructed to use single core stranded copper PVC insulated cables to BS6004 and steel trunking to erect and wire the electrical installation. The first section of trunking from the Distribution Board will contain the circuits given in Table 4.1. Using the given tables, 4.2 and 4.3 calculate the correct trunking size to be used in the first section of trunking from the Distribution Board. (6 marks)

Circuit No	Number of cores	CSA in mm ²
1	3	4
2	4	10
3	5	6
4	3	1.5
5	4	16
6	4	25

Table 4.1

Type of conductor	Conductor cross-sectional area (mm ²)	PVC BS 6004 cable factor	Thermosetting BS 7211 cable factor
Solid	1.5	8.0	8.6
	2.5	11.9	11.9
Stranded	1.5	8.6	9.6
	2.5	12.6	13.9
	4	16.6	18.1
	6	21.2	22.9
	10	35.3	36.3
	16	47.8	50.3
	25	73.9	75.4

Table 4.2 Cable factors for trunking

Dimensions of trunking (mm x mm)	Factor	Dimensions of trunking (mm x mm)	Factor
50 x 38	767	200 x 100	8572
50 x 50	1037	200 x 150	13001
75 x 25	738	200 x 200	17429
75 x 38	1146	225 x 38	3474
75 x 50	1555	225 x 50	4671
75 x 75	2371	225 x 75	7167
100 x 25	993	225 x 100	9662
100 x 38	1542	225 x 150	14652
100 x 50	2091	225 x 200	19643
100 x 75	3189	225 x 225	22138
100 x 100	4252	300 x 38	4648

Table 4.3 Factors for trunking

- (c) (i) With the aid of a diagram explain how two steel trunking lengths are joint together. (3 marks)
- (ii) Referring to Table 4.1, explain how the circuits mentioned in the table are arranged in the trunking enclosure according to IET regulations. (2 marks)
- (d) (i) List and briefly explain the **THREE** essential components that form a busbar trunking. (3 marks)
- (ii) Mention **ONE** advantage and **ONE** disadvantage of busbar trunking system. (4 marks)

5. The 3-phase load profile of a factory is given in Figure 5.1. The load profile replicates every week and has the same pattern. A 60-minute snapshot of this repetitive load profile is shown in the figure below.

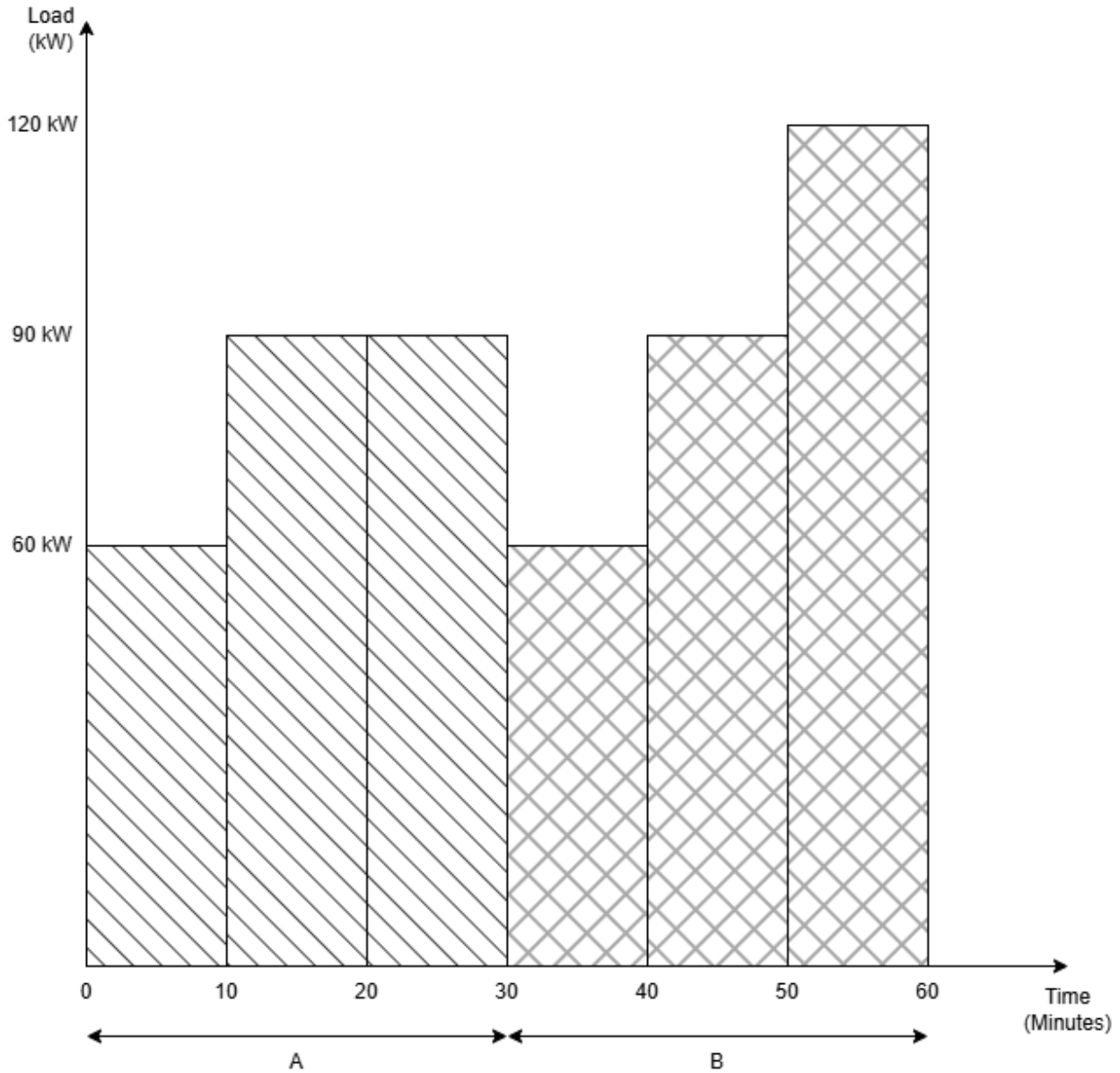

Figure 5.1

- From the profile Figure 5.1, calculate the total kWh for the 60-minute period. (6 marks)
- Given that the tariff is € 0.24 per kVAh unit, calculate the daily cost, given that the overall Power factor is 0.9 and the profile in Figure 5.1 is repeated for 8 hours. (6 marks)

- c) The maximum demand is calculated as follows: the energy meter registers the maximum average load over a 30-minute period. Calculate the average load in kW for the first 30-minute load profile and then for the second 30-minute. (6 marks)
- d) Given that the maximum demand tariff is €15.00 per kW calculate the maximum demand cost if this load profile operation is the same per annum. (2 marks)

6. The diagram in Figure 6.1 shows two transformers (A and B) with isolated primary and secondary. Transformer A has 0° phase shift while Transformer B has its secondary wound anticlockwise or in reverse to the primary and has a 180° phase shift.

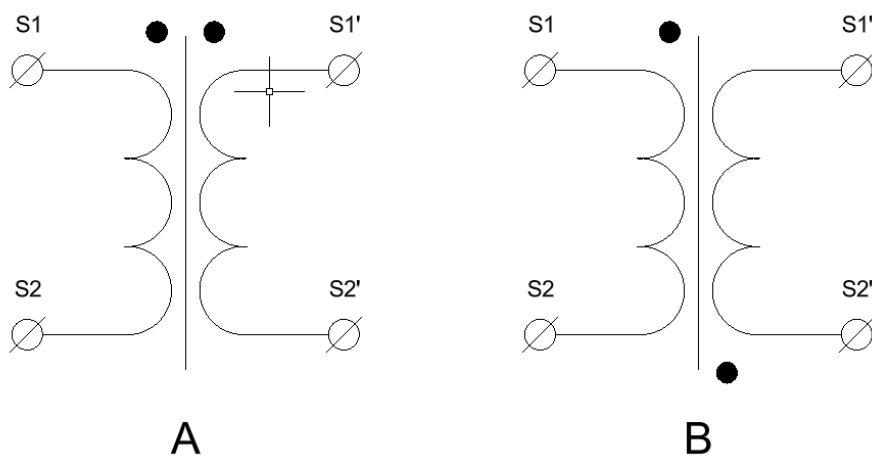

Figure 6.1 – Transformers with 180° phase shift



Figure 6.2 - Galvanometer

You are provided with a Galvanometer, as shown in Figure 6.2, together with a proper resistor in series (to limit the current) and a 6V DC battery.

- (a) For each transformer, the battery is connected to the primary between S1 (+ve) and S2 (-ve) and the Galvanometer is connected to the secondary S1' (+ve) and S2' (-ve). In which direction will the Galvanometer go for each transformer test? Give reasons for your answers. (4 marks)
- (b) A customer calls an authorised person to connect a motor to his system. The authorised person notes that the motor is with 6 tails terminated on lugs without any identification and not terminated on the terminal block as shown in Figure 6.3. The motor was a replacement found in the store. What are the six terminations for? (2 marks)

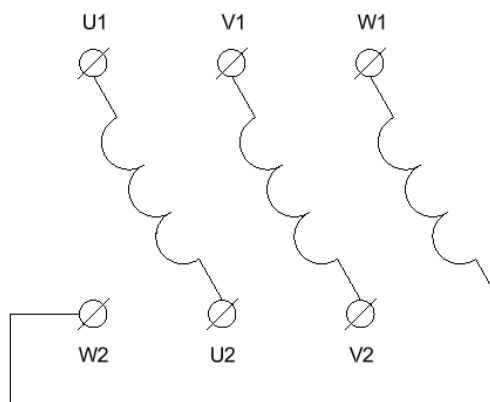

Figure 6.3 – Motor Terminal Block

- (c) State the tests that you will carry out to
- (i) identify the separate coils of the motor windings (3 marks)
 - (ii) check if any coil has a leakage current to earth. (1 mark)
- (d) From the principle of the transformer action in part (a) of this question
- (i) State if one can use the same test method to identify the correct polarity of each coil. Give reason for your answer. (3 marks)
 - (ii) Explain what happens if one of the coils is connected in the wrong polarity with respect to the other two coils. (2 marks)
 - (iii) Write the test that needs to be conducted to identify the correct polarity of each motor coil. (5 marks)

END OF EXAMINATION PAPER